

**EXCEEDING
EXPECTATIONS**

About Us

BRIGHT LIGHT ELECT. SWITCHGEAR ASSEMBLY is a complete solution of Electrical Distribution systems & Industry Expert for Fabrication. Our expertise has over 20 years of work experience in this field. In all aspects of electrical systems including creative lighting design, power distribution, UPS and emergency power, communications systems and special control systems in both the public and private sectors. The people of Our Company have made a commitment to deliver the highest quality of electrical systems design. Informed by current technologies, budget schedule, and client priorities, they strive for perfection in service and product. Excellence and innovation describe the reputation, which they expect will become synonymous with the name BLESA.

Switchgear & Electrical Assembly

Bright Light Electrical Switchgear Assembly has decades of experience in the switchgear & electrical assembly industry, and we are able to provide a fully customized increased safe area assembly and wiring service of safety enclosure and components.

Our Experienced Teams are highly skilled and deals with assembly of safety enclosures, control panels, distribution boards junction boxes, terminal boxes, instrumentation boxes, lighting assemblies, and general electrical assemblies in a wide variety of materials including; stainless steel, aluminum, GRP and plastic, and are able to offer a customized painting service if required. We are supplying cable and electrical products and services to major oil and gas companies in the middle east.

Fabrications & Mechanical Division

Bright Light as fabricators is a name known for reliability and continuous improvement in the field of all types of metal fabrication for oil fields, Malls, complexes, Organizations, and showrooms. Our focus is to create pleasing fabrication & Mechanical work and provide high-quality fabrication designs to our clients.

We offer a full range of fabrication design and architectural services which include planning, designing, supervising quality control, and coordination of the entire project. We endeavor to offer unparalleled fabrication and designing products of the highest quality. We take strict measures to maintain the desired quality standards at all levels.

"We Provide Quality Products
through Quality Services"

Experience and process knowledge

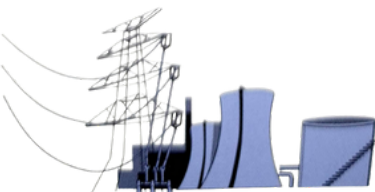

Power Generation Distribution & Utilities

Our broad range of activities allows the company to offer multiple products and services in specific markets such as oil & gas, power generation, transportation, telecommunication, water, commercial buildings etc.

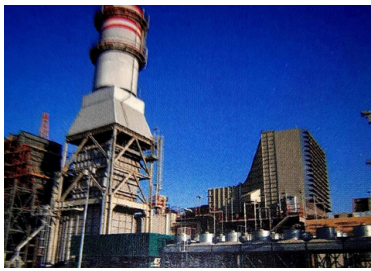

Telecommunication

We offer engineering expertise, quality products and services to build a solution to help improve your productivity and profitability. We are listening to your needs by fully understanding your market. Our open-system solutions provide the ability to upgrade in future, improve efficiency and reduce downtime.

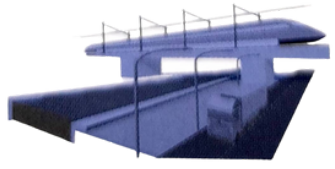
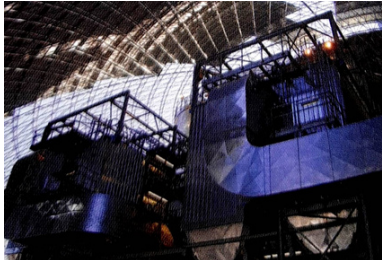

Transportation & Infrastructure

We propose global and innovative solutions for electrical distribution, control elements and automation systems. We offer engineering expertise, quality products and services to build a solution to help improve your productivity and profitability. We are listening to your needs by fully understanding your market.

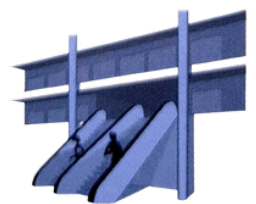

Commercial Buildings

Solar power systems are integrated into outdoor enclosures and other mechanical structures. Solar energy is the cleanest and most abundant renewable energy source available. This energy can be used to generate electricity or be stored in batteries or thermal storage.

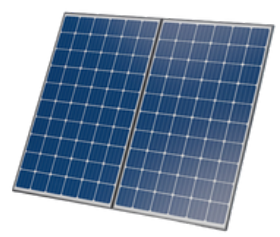

Solar Power System

Industrial Circuit Breakers



Air Circuit Breakers (ACB)

- EntelliGuard
- Mpack Plus
- PowerBreak II
- Waveprol
- AK/AKR
- In all Amps
- Short circuit ratings upto 200 kA



Molded Case Circuit Breakers (MCCB)

- Record Plus
- Spectra
- TEY/sTEY
- In all amps
- Short circuit ratings upto 150 kA
- Electronic and thermal magnetic trips

Modular

Miniature Circuit Breakers (MCB)



- In all amps
- Short circuit ratings 25 kA
- 18 mm modular width per pole
- Residential, commercial and Industrial applications

Residual Current Devices (RCD/RCBO)



- In all amps
- People protection against electrocution 10 mA, 300 mA and 100 mA and above

Energy Management

- Timers
- Switches
- Surge arrestor
- Measurement devices
- Reconnectivity devices



Utility Devices

- Utility breakers for residential applications (ICP, ELCB)



Controls

Power Devices - IEC

- Contactors
- Starters
- Relays
- Manual motor starter
- Overload relay



Power Devices - NEMA

- Contactors
- Starters
- Combination starters
- Pump panels
- Reduced voltage starter panels
- Bi - metallic and electronic overloads



Drives

- General Purpose Fan and pump applicator upto 1000 kW
- Built in filters
- Communication
- Built in EMC filter
- Built in PID controller
- Hot pluggable Key pad
- Easy to install
- User friendly PC software



Soft Starters

- Light & Heavy duty applications upto 1000 kW
- Built in filters
- Built in EMC filter
- Hot pluggable Key pad
- Easy to install
- User friendly PC software



Pilot Devices - IEC

- Push Buttons
- Pilot Lights
- 22 mm size
- Selector switches
- Rated for NEMA 1, 3, 3R, 3S, 4, 4x, 12, 13 and IP66



Pilot Devices - NEMA

- Push Buttons
- Pilot Lights
- Selector switches
- 30 mm and in 22 mm sizes
- Rated for NEMA 1, 3, 3R, 3S, 4, 4x, 12, 13 and IP66



Transformers

Wavecast: Designed for utility grid, industrial and commercial application such as oil and gas, chemical, cement and mining

- Liquid - filled
- ventilated dry-type (Wavecast)
- Cast coil
- Padmounted

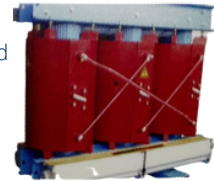

Surge Protection Devices

Designed to protect electronic and electrical equipment from the damaging effects of internal and external electrical surges

- DIN Rail - modular, low cost point-of-use protection
- Integrated protection for electrical distribution equipment



Safety Switches

- General & heavy Duty in all amps are available
- In 2, 3 & 6 poles with maximum voltage rating Vac
- Sheet steel enclosures, GRP and Polyamide offers superior rust protection in a outdoor applications



Low Voltage Distribution

Sub Main Distribution (SMDB)

- Wall mount or free standing enclosure
- Up to FORM-4B for free standing enclosure using RiPower technology
- Type tested according to IEC 61439 and design verified
- Wall mount enclosure will be either with custom busbar or pre-fabricated tinted busbar for EasyPact breakers same technology as final distribution boards
- Customized solutions for mission-critical applications



Low Voltage Equipment

Motor Control Center (MCC)

We offer an extensive range of MCC Panel (Motor Control Center) which can be fully drawn out with incoming and outgoing feeders or non draw out type. The MCC Panels are extensively used for reducing start voltage, reversing control or varying the speed as per requirement and for protection against overloads and faults.



Final Distribution Board

FDB IEC Panels

LV Distribution panels up to 250A, for commercial and industrial market segments

- Electro Galvanized Steel Sheet 1.5/2mm
- Manufactured Form 2
- Index of protection IP 4x & IP 65
- Suitable for both internal & external mounting (Weather Proof with Canopy)
- Custom design according to client requirement



Busway

Serves commercial, industrial and utility segments and complies with UL, NEMA, IEC and GB standards. Spectra series busway is at least 50 percent lighter than comparable wire and conduit.

WavePro-F, new-generation fire-resistant busway, features extensive fire-resistant performance of up to 950°C for 180 minutes and IP68. suitable for emergency generator circuit of high-rise commercial building and shipyard.



Uninterruptible Power Supplies (UPS)



Single Phase

Delivering reliable power in a compact package for smaller power applications such as IT networks and critical processes



Three Phase

Providing clean, reliable and efficient power with battery backup for large power applications such as data centers, hospitals and critical operations.

Smoke Mgmt. System

Mimic Panel

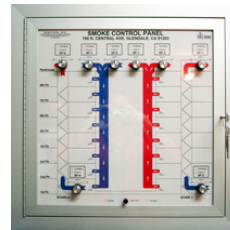

- Panels for front view suitable for building application
- Enclosure Sheet steel or Stainless steel
- Custom design according to client requirements
- Multicolor option as per client requirement

PCB Designing

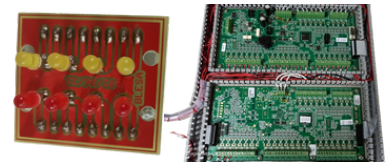

BLESA Provide PCB Assembly Services including PCB Designing diagram, PCB board, LED circuit & display board circuit as per customers Specification.

Electrical Assembly



Junction Box

BLESA Provide complete assembly of Stainless Steel GRP and Aluminum JB's, Termination, earth continuity, cable entries as per the drawing specially we are doing free holes and threaded holes with different pitch size ensuring IP rated protection. Also doing JB's modification as per customers specification.



Control Stations

BLESA Provide complete assembly & wiring of stainless steel, Aluminum & GRP control stations. Especially Drilling Push button holes and cable entries ensuring IP rated protection as per the customers drawing requirement.



Cable Termination

BLESA Assembly cable termination with all sizes of terminals with cable lugs & cable marker. We are using PVC Type & Heat Shrink Ferrule tube for addressable ferrule marking.



Painting & Reassembled

BLESA Provide high international quality standards, Painting and Metal Coating services as per customers requirement especially, all type of Stainless steel, Aluminum, GRP & Polyamide Enclosures.

Junction Boxes

We distribute standard type IP rated, safe area, flame proof, explosion proof junction boxes complete fitting with terminals and glands.
Materials:- Stainless steel, GRP polyester, aluminum



Control Stations

We are dealing with control station standard type & customized flame proof, explosion proof as per customers requirement. Complete assembly with switches, push buttons, pilote lamps and glands.
Materials:- Stainless steel, Aluminum, GRP polyster & polyamide



VFD (Variable Speed Drive)

BLESA deals with high-quality variable speed drive used to control motors. It will be available in 0.37 - 250 kW, 115V - 600V power range.



Street Light Fuse Cut-out

BLESA deals with all types of fuse & MCB Cutout for lighting poles. We are supplying 1- 4 way fuse & MCB cutout with brass gland for incoming cable and PVC gland for outgoing cable as per customers requirement .



Industrial Type Socket and Plugs

We are distributing industrial plug & socket standard IP rated, Safe area, flame - proof and explosion - proof available in All - pole, All - Voltage & All - current rates.



Ammeters

A full range of Analogue Meters available to monitor various electrical parameters such as Voltage, Current, Power, Frequency, Maximum demand etc. in 48x48, 72x72, 96x96, 144x144 sizes with 90° and 240° Scale

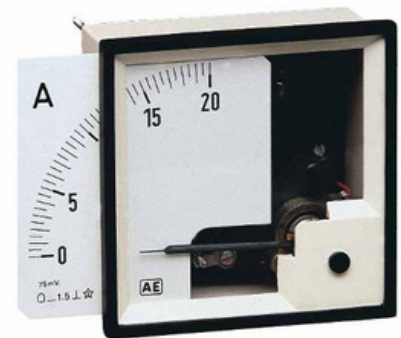

Terminal

We are supplying

- Screw Clamp terminal blocks
- Push - In Terminal Blocks
- Spring Clamp Terminal Blocks
- Stud & Bolt type Terminal Blocks
- Melamine Terminal Blocks
- Slim Relays Terminal Blocks

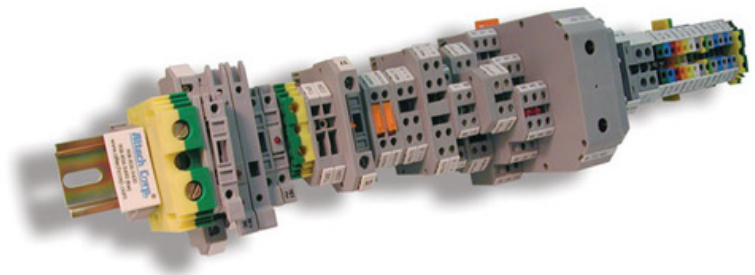

Busbar

We are supplying

- Copper Bars are Available in Flat, Round, Square and Hexagonal
- Tinned Copper Busbar
- Maxiflex insulated flexible isolated bar

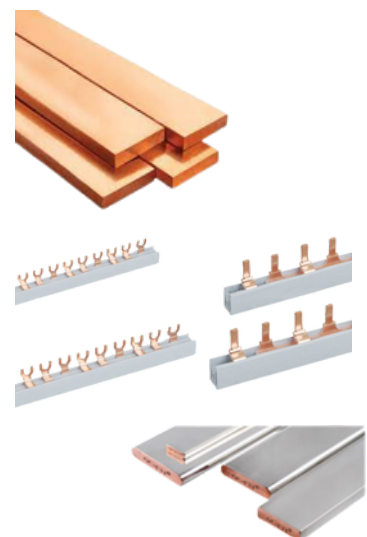

Din Rail & Accessories

- Din Rail, G Rail - available in Galvanized Steel, Stainless Steel & Zinc Coated Types.
- Elevation Spacer Bolts & Spacer available in Galvanized Steel, Stainless steel & Zinc coated types.
- Padlock Facility for E-Stop Push Buttons
- Bus Bar Insulators



Cables



Tinned Copper Cables

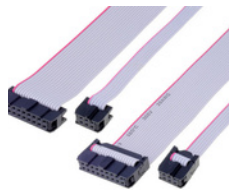

Ribbon Cables

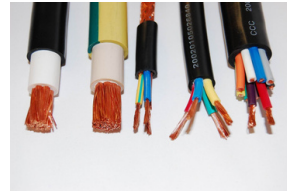

Multi-Core Cable PVC



Armoured Cables



Fire Cables



Heat Proof Cables



Flexible cables



Cable Sleeve

Cable Management Accessories

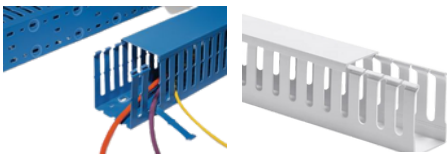

Slotted Type Wiring Ducts



Cable Tube Markers

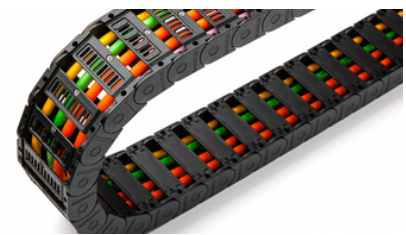

Energy Chain



Cable Lugs

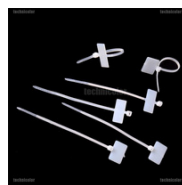

Cable Tagging Tie



Cable Tie Base



Cable Gland



Cable Marking Ferrule

ENGRAVING DIVISION

We have fully equipped computerized engraving facilities for all kind of industries like Electrical Switchgear, Construction, Hotels and Offices etc. We undertake all kind of signage work for these industries to their customized requirement, especially in arabic text.

Facilities

- All kind of engraved identification label in PVC, Traffolyte, Acrylic, Aluminum, Brass, Mild steel and stainless steel.
- Manufacturing Labels for the Switchgear industries machinery etc.
- Mimic diagram with size of 1800 x 1200 mm and Mimic Symbols
- Screen Printing





MILD STEEL FABRICATION | STAINLESS STEEL FABRICATION | ALUMINIUM FABRICATION

The facilities we offer include

- Laser Cutting Service
- CNC Punching
- Bending Works
- Drilling & Tapping
- Lathe Works
- Grinding, Welding & Polishing especially (S.S Material)
- Hard Chrome plating
- Electro Galvanized
- Hot Deep Galvanized
- Heavy duty jobs for various industries

Our Activities

Steel Fabrication Division

Supply, Fabrication, Blasting, Painting, and Erection of structural steelwork which includes, large and medium jobs. We take care of the job for the following Industries: Power plants, Petrochemical industries, heavy & medium manufacturing industries, warehouse, all kinds of buildings, Grand Stands, Stadiums, Multi Storey Structured, Bridges, Floating Pontoons and all other cladding works.

Main Activities

Steel structures for sheds, Car sheds, Mezzanine floors, Staircase, Roofing sheets, Handrails, Platforms, Walkways, Ladders, Gates & Grills, Metal staircase, Rolling shutter doors, Storage tanks, Tents, Spiral staircase, Trench railings, Machinery and services, Stainless steel handrails, Cladding of columns, Frames etc.

Machine Shop (Tool Room) Division

Manufacturing, Re-conditioning, Machining, Electroplating etc to service the following Industries: Oil & Gas, Marine & Ship repair, Mining & Quarries, Cement & Construction, Paper & Printing, Aviation, Food Processing, and all other manufacturing industries.

Enclosures

We fabricate all types of Customise enclosures in stainless steel GRP & sheet steel. Specially all kind of enclosure modifying as per the requirement of the customers.



Rack Cabinets

We fabricate and design 19-inch Rack Cabinet Standard and fully Customised as per the customers Requirement. Especially for fire equipment & emergency safety system as per the manufacturers suggestion. Also accessories fabricating rail, dummy plates, base plates & hardware.



Cabinets

We fabricate all kind of standard and customized cabinet with glass door and shelf type.

Materials:- Sheet steel and Stainless steel



Framework

We fabricate standardized wall - mounting & free standing frameworks for distribution panels & wall sockets junction boxes.

Materials:- Sheet steel with Hot dip galvanized, Sheet steel with epoxy coated, Sheet steel with Electro galvanized & Stainless steel



Canopy

We fabricate all kind of standard & customized canopies as per the drawing specification.

Material:- Stainless steel, Sheet steel, Aluminum, GRP, Galvanized steel & Sheet steel with epoxy coated

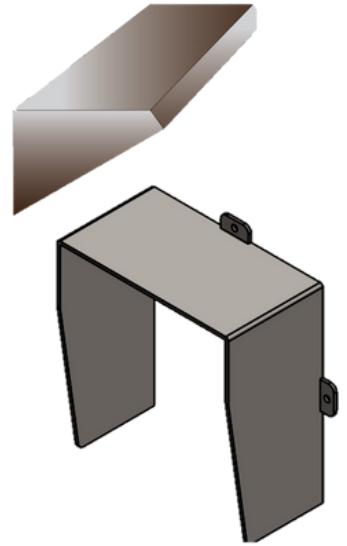

Pipe Clamps & Wall Mounting Brackets

We fabricate pole mounting & wall mounting brackets for light fittings, cameras & junction boxes.

Materials:- Galvanized steel, Sheet steel with hot dip galvanized, Sheet steel with epoxy coated & Stainless steel



Mounting Plate

Mounting plate fabricated for junction boxes, control panels & lighting systems.

Materials:- Galvanized steel, Stainless steel, Bakelite sheet, Sheet steel insulated type

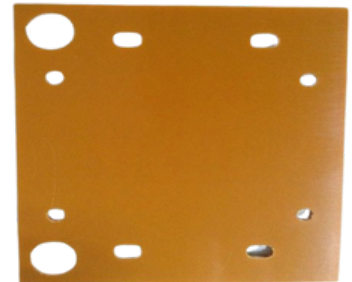

Gland Plate

All type of electrical enclosure gland plate we fabricated with IP protection gasket & earth stud welded as per customer requirement.

Materials:- Sheet steel with powder coated, Knockout gland plate, Stainless steel



Cable Tray & Accessories

Types of cable tray we supply

- Ladder type cable tray
- Solid bottom cable tray
- Trough cable tray
- Channel cable tray
- Wire mesh cable tray
- Single rail cable tray
- Cable tray accessories & hardwares

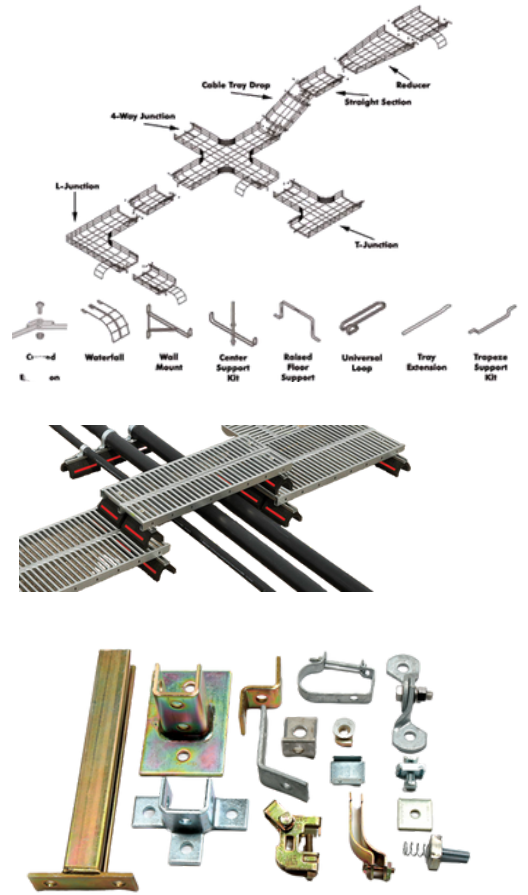

Light Enclosure

We design & fabricate spotlight enclosure in cylindrical type, cube type & square type in steel powder coated & aluminum.
Materials:- Galvanized steel, Sheet steel with hot dip galvanized, Sheet steel with electro galvanized, Sheet steel with epoxy coated & Stainless steel



Display Board

We design & fabricate standard and customized demo display board, demo carry cases & pelican cases for exhibition & display as per customer requirement in wooden, steel, aluminum & stainless steel.



Pocket for Electrical Cabinet

We fabricate wiring plan pockets & document storage pockets in plastic, steel and stainless steel to suit all sizes of enclosure.



Lighting Reflector

We fabricate lighting strip reflector for fluorescent fittings in aluminum sheet-steel & stainless steel.



Pole Adapter

We fabricate pole adapter, slipfitter bracket, T-bracket, spool adapter for light fixtures & camera mounting in steel, stainless steel & aluminum.





Aluminum

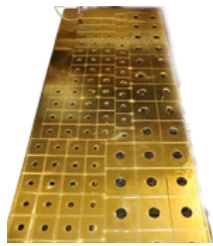

Brass

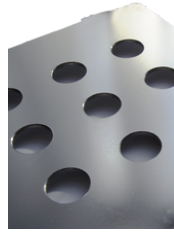

Stainless Steel

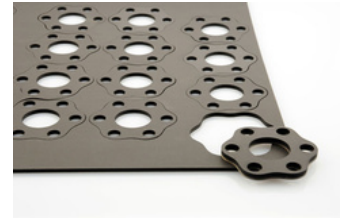

Sheet Steel



Mild Steel U-Bracket



All kind of Radius type bracket

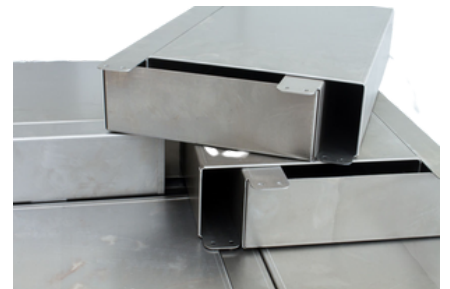

Stainless Steel Sheet

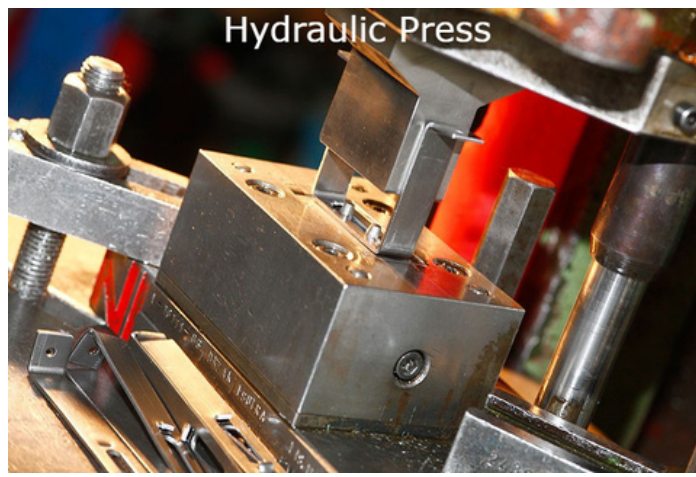

Module Box Di Press



Embossed Di Press for Threading

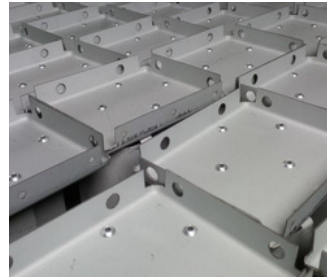

Embossed Round Hole Di Pressed



Hole Punching



Gland Plate Stud Weld

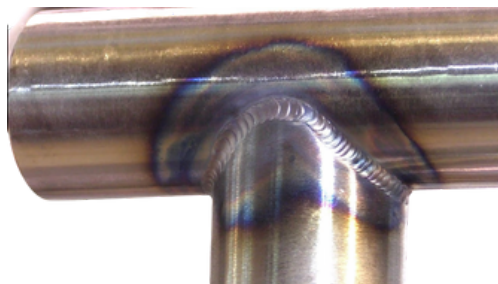

Carbon Steel



Aluminum



Stainless Steel

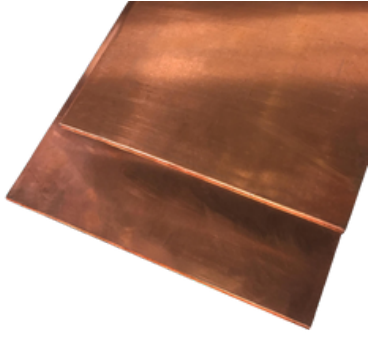

Copper Sheet

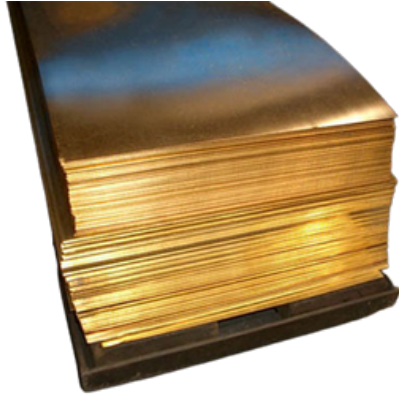

Brass Sheet

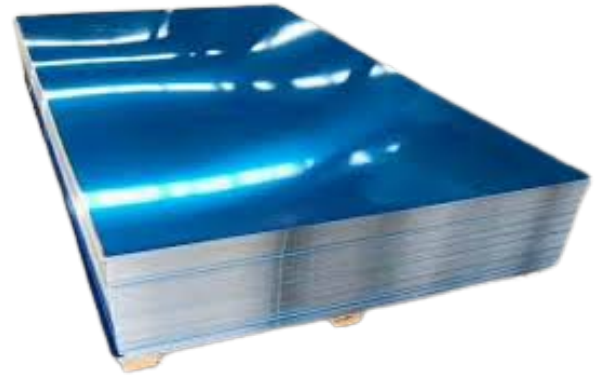

Aluminum Sheet

Tools & Hardware

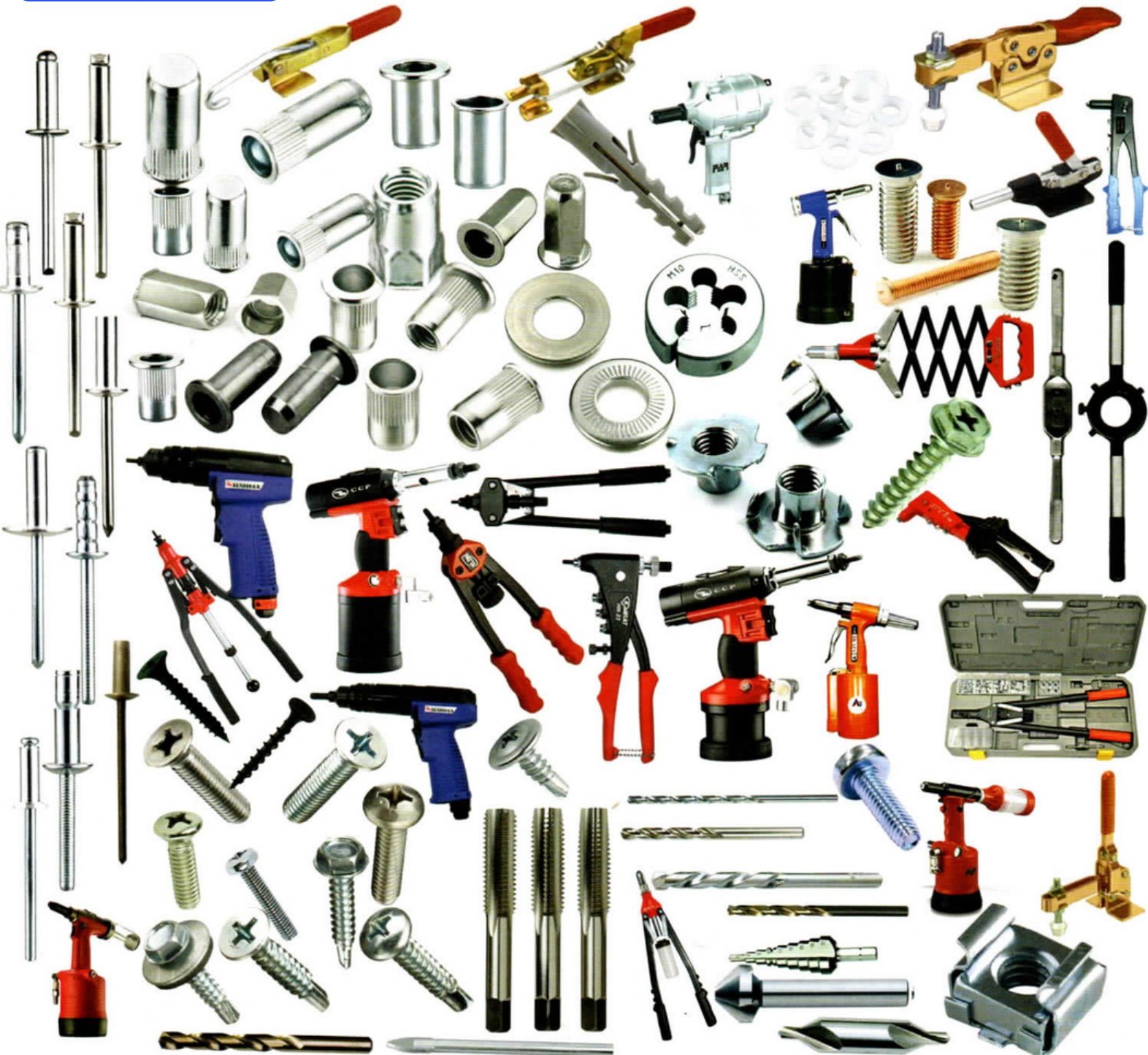

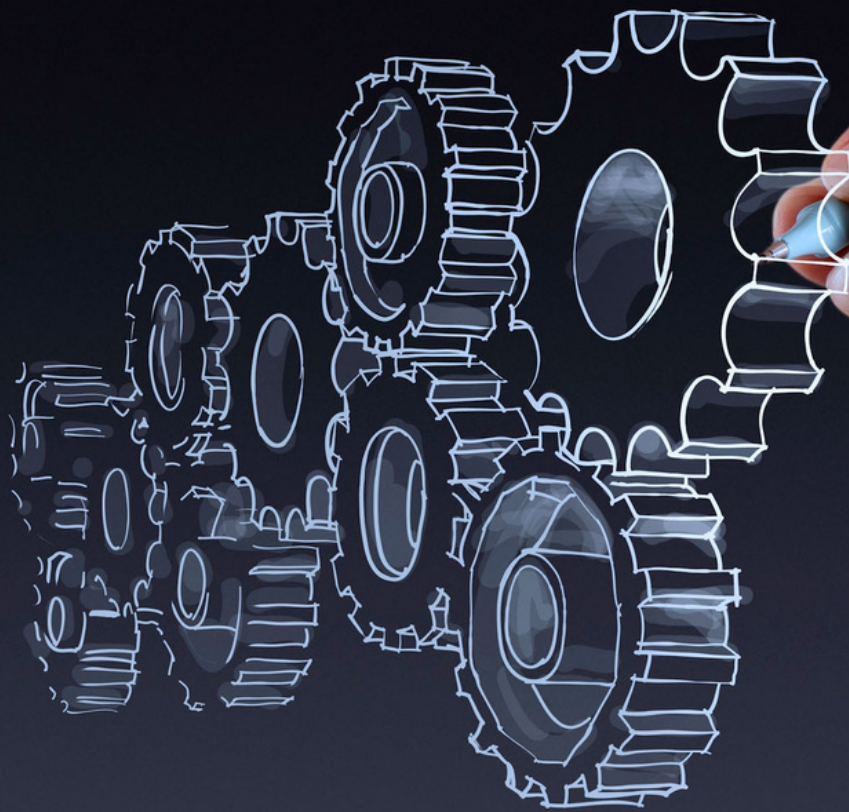

Quality Without Short-Cuts

Comprehensive quality assurance system - Certified, of course, to the latest directives ISO 9001-2015 - are the basic for our day-to-day behaviour.

Before our products are made available to you, we ensure that they fulfil even the stringent requirements because you must be able to rely on them in an emergency.

Our technical solutions protect both property and life. Our customers view us as a trusted partner for safety. Quality has a top priority for our highly qualified employees and governs their actions.

This pays off because our services must remain fully functional at all times, even under adverse ambient conditions.

Bright Light Electrical Switchgear Assembly

Sajaa Industrial Area, Near Emirates Gas Operation Sajaa
P.O Box 28888, E-mail : bleswgr@gmail.com
Tel : +971 6 5446551, Mob : +971 50 5657571
Sharjah, United Arab Emirates



www.bleswgr.com

Bright Light Electrical Switchgear Assembly

Sajaa Industrial Area, Near Emirates Gas Operation Sajaa
P.O Box 28888, E-mail : bleswgr@gmail.com
Tel : +971 6 5446551, Mob : +971 50 4946786
Sharjah, United Arab Emirates